

The MiniTower™ GOTO AltAz Mount with GPS and dual Mount set-up #8300



FEATURES

- 25 lb Payload
- 8 lbs of additional payload on the balancing side
- All metal (aluminum alloy and stainless steel) heavy duty tripod
- 1.5"/1.25" stainless steel legs
- Internal GPS
- GOTO NOVA #8401 controller with USB port and 130,000 objects in database
- Accurate SmartStar® GoTo and auto-tracking
- Conical bearings, 4 steel ball bearings
- Metal worm/gears
- Automatic over-current protection
- Automatic clutch protection for both axes
- Typical GoTo accuracy: 1 Arc Min.
- Resolution: 1 Arc Sec.
- Dual scope setup with two dovetails
- High accuracy level indicator
- 3-point easy level adjustment system
- Manual push-to for both axes

PACKAGE CONTENTS





- Telescope Mount (with built-in GPS)
- #8401 Hand Controller
- Controller Cable
- 1.5-inch Tripod
- Tripod Rod
- Tripod Support
- Tripod Knob
- Tripod Lock
- 10lb (4.5 kg) Counterweight
- Counterweight Brass Pin
- Counterweight Lock
- Counter Balance Arm
- Counter Balance Arm Lock
- Azimuth Lock
- Altitude Lock
- Primary Dovetail Lock
- Primary Dovetail Holder
- Secondary Dovetail Holder Lock
- Secondary Dovetail Holder
- Secondary Dovetail Lock
- AC adapter
- USB cable
- 12V DC adaptor cable with car lighter plug
- Hard travel case





ONLINE CONTENTS *(click under "Support" menu)* www.iOptron.com

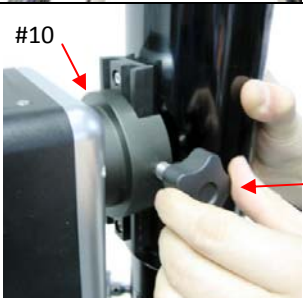



- Manuals *(you will need to refer to the full manual for details on set-up and operation).*
- Tips for set up
- Hand controller firmware upgrades *(check online for latest version)*
- Reviews and feedback from other customers

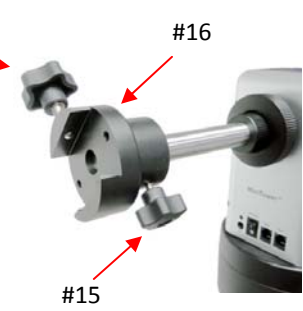

Quick Set-up

Note: This is a brief outline for getting started. Please refer to the full manual at www.iOptron.com for details.

	<p>Step 1. Extend tripod legs to full extension. Then lock legs using the lock knobs on sides.</p>
	<p>Step 2. Carefully position telescope mount onto the tripod by aligning the three holes onto the matching three pins.</p>
	<p>Step 3. Secure the mount to the tripod by using the long rod (#4). Hand tighten the rod into the bottom of the mount. Next, slide tripod support (#2) onto bottom of rod (#4). Position the three edges to fit against the three tripod legs. Then hand tighten tripod lock knob (#1) to secure the tripod support in place.</p>
	<p>Step 4. Attach telescope to primary dovetail holder (#10) using primary dovetail lock (#9).</p>
	<p>Step 5. Set telescope to PARK POSITION. (1) Position the mount so that the "S" is facing south. (2) The telescope tube should be pointed directly up at the zenith. If it is not perfectly straight then loosen the altitude lock (#13) to adjust telescope. Once it is straight re-tighten the altitude lock to make sure OTA is secure and will not spin.</p>

	<p>Step 6. This step allows you to attach the counterweight or a second scope. (<i>note: if you have a light scope less than 10 lbs. on the primary side, then attaching a counterweight is optional</i>).</p> <p>First, make sure altitude lock (#13) is tight (see step 5). Screw the counterbalance arm (#18) into the threaded hole in altitude lock (#13) and tighten the counter balance arm lock (#14).</p>
	<p><i>If you are attaching a second scope do not add the counterweight. Instead, skip to Step 9 to add a second scope.</i></p> <p>Step 7. Slide the counterweight onto the counterbalance arm (#18). Next, insert the brass pin into the hole on the counterweight. Note: when tightened this brass rod should fit into the groove of the arm.</p>
	<p>Step 8. Secure the counterweight by tightening the lock knob. Again, the counterweight should fit over the groove of the arm so that the brass rod fits into the groove when tightened.</p> <p>Next: Skip to step 10.</p>
	<p><i>This step is for attaching a second scope. Go to steps 7 and 8 if you are attaching the counterweight.</i></p> <p>Step 9. Attach Secondary Dovetail Holder (#16) by tightening the holder lock (#15) onto the counterweight arm (#18).</p> <p>After sliding your scope into the dovetail holder—secure the scope by tightening the secondary lock (#17)</p>
	<p>Step 10. Level the mount using the bubble on side of mount by adjusting the three metal adjusters (see step 2 for picture). Use the top section (#6) to make adjustments. Use the bottom section (#5) to lock the position. It is also suggested to use additional levels to assure very precise level. Turn the mount to make sure it is leveled in all directions.</p>

	<p>Step 11. Plug in power plug and hand controller.</p>
	<p>Step 12. Turn on and wait for controller lights to come on. (For GPS signal, wait for controller to say “GPS OK”—not “GPS ON”).</p> <p><i>GPS provides Latitude, Longitude, and current time only. This information can also be inputted manually.</i></p>
	<p>Step 13. Go to: Set up controller. Press ENTER.</p>
	<p>Step 14. Go to: Set up Local Time. Press ENTER.</p> <p>Enter date and day-light savings (Y=yes. N=no). Then press ENTER</p> <p><i>(Note: use numbered keypad to change numbers)</i></p>
	<p>Step 15. Go to: Set Up Site. Press ENTER. Enter time zone: <i>(add or subtract 60 minutes per time zone)</i></p> <p><u>Enter minutes “behind” UT or “ahead” of UT</u></p> <ul style="list-style-type: none"> • New York City is 300 minutes “behind” UT • Los Angeles is 480 minutes “behind” UT • Rome is 60 minutes “ahead” of UT • Sydney is 600 minutes “ahead” of UT

	<p>Step 16. Select and Slew to an object The mount is now ready to GOTO and track objects.</p> <p>Go to: Menu>Select and Slew Press ENTER.</p>
	<p>Step 17. Select a category (ex. “planets, sun, moon”). Then select an object (ex. “moon”). Then press ENTER.</p> <p>The telescope will automatically slew to the object and lock on. It will automatically begin to track once it locks on to the object.</p>
	<p>Step 18. Sync to Target <i>(Use this to center and synchronize the object from Step 17 into the memory).</i> Go to: MENU>Sync. To Target. Press ENTER. Next use the arrow keys to slew to the object until it is centered in your eyepiece. Then press ENTER again on the hand controller.</p> <p>To slew to other objects repeat steps 16 and 17. You do not need to repeat step 18 except for adjustments. <i>(Refer to the online manual for 1-star and 2-star alignments. Sync to Target is the same as 1-star Alignment except that you choose the object to align to.)</i></p>
Additional Features/Tips	
	<p>Backlash Default is 150. If experiencing “jiggle” motion try adjusting backlash to 0.</p>
	<p>Mount Mode/Type When setting up hand controller check to make sure mount mode is AltAz and not EQ.</p>
	<p>Error message?: DEC/RA Overcurrent Check your OTA balance and/or power supply first.</p>
	<p>Level the Mount Level the mount before installing the OTA to make the final leveling easy</p>
	<p>Stop/0 The Stop button is used to stop the tracking. It does not stop slewing. To stop the slewing press the “back” button.</p>
	<p>Slew Speed To change the slew speed use the number keys 1 through 9. 1-1x speed. 9- MAX speed (1056x).</p>

MiniTower Components

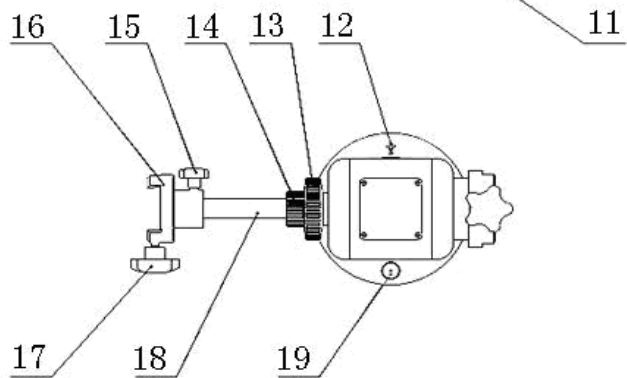
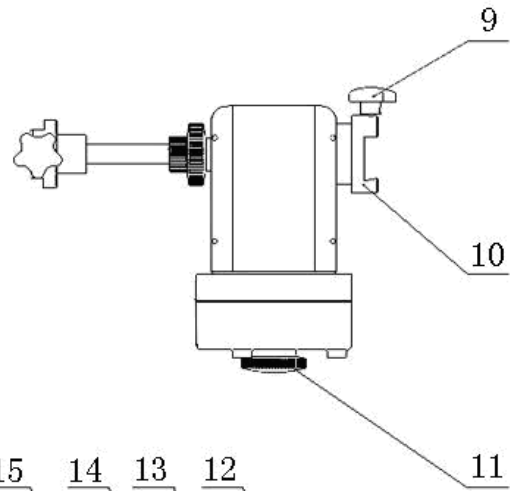
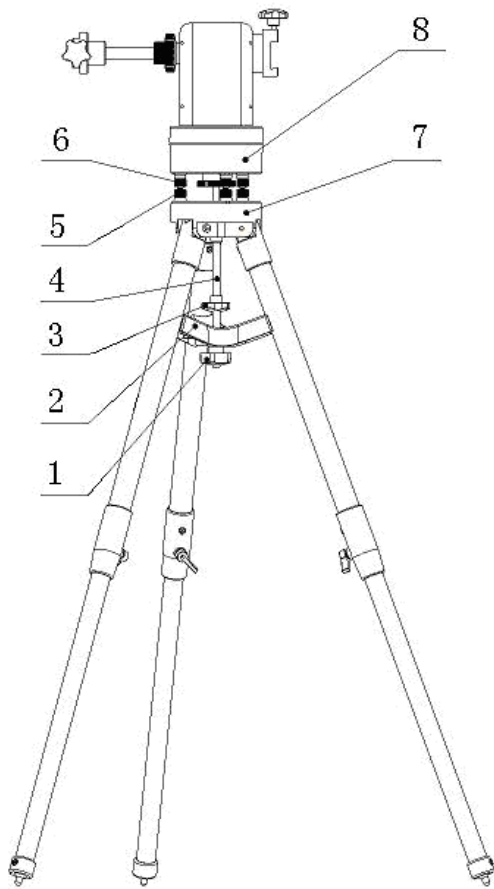

1. Tripod Lock
2. Tripod Support
3. Tripod Knob
4. Tripod Rod
5. Level Adjustment Lock
6. Level Adjustment Screw
7. 1.5-inch Tripod
8. Mount Base

9. Primary Dovetail Lock
10. Primary Dovetail Holder
11. Azimuth Lock
12. South Mark
13. Altitude Lock
14. Counter Balance Arm Lock
15. Secondary Dovetail Holder Lock
16. Secondary Dovetail Holder
17. Secondary Dovetail Lock
18. Counter Balance Arm
19. Bubble Indicator